

# ELMO

## HC7001

### High Resolution 1/2" Color CCD Camera



### Industrial / OEM General Camera Module

#### OVERVIEW

The HC7001 has been specially designed as a ruggedized general purpose high resolution color video camera to be used wherever applications require a 1/2" CCD sensor. The HC7001 is capable of handling tasks from monitoring to machine vision.

All the controls are accessible externally making the camera very user friendly.

The Y/C 480 TV(H) lines resolution coupled with a 1.8 lx sensitivity and 50dB S/N affords video of the highest quality attainable from a single CCD.

Of course, there is complete versatility with electronic shutter control both automatic and manual.

The HC7001 is extremely compact and lightweight so that the applications in which it can be used are nearly boundless.

#### FEATURES

- 1/2" IT HAD Color CCD
- 768 (H) x 494 (V) pixels
- 480 TV lines (H) resolution
- 50dB S/N
- VBS and Y/C outputs
- Digital signal processing
- AGC ON/OFF switch
- Selectable white balance mode
- Manual shutter or fully auto shutter speed (AES)
- Accepts video or DC type auto iris lenses
- Accepts both CS/C mount lenses
- Compact body only 2-1/4 x 2-1/4 x 3-1/2"
- Light weight only 12 oz

# ELMO

Visualizing technology since 1921

# High Resolution 1/2" Color CCD Camera Industrial / OEM Camera Module

# HC7001

## SPECIFICATIONS

Image Sensor	1/2" Interline Transfer Color CCD
Effective Pixels	768 (H) x 494 (V)
TV System	NTSC 2:1 Interlaced
Synchronization	Internal
Resolution	480 TVL(H), 350 TVL (V)
S/N Ratio	50dB at AGC OFF
Min. Sensitivity	1.8 lx @ F1.2
AGC	ON-OFF switch built-in
White Balance	ATW/AWC/Preset
Electronic Shutter	1/60, 1/100, 1/250, 1/500, 1/1,000, 1/2,000, 1/4,000, 1/10,000sec.
Automatic Shutter	Built-in, 1/60 - 1/100,000sec. linear
Video Outputs	VBS: 1.0Vp-p 75 ohm BNC Connector on back panel Y/C: 6P Connector on back panel
Auto Iris Lens	DC/Video, 4P Connector on side panel
Lens Mount	CS Mount/ C Mount with supplied 5mm ring
Power Source	DC12V (DC11V - 16V) 6P Connector
Dimensions (WxHxD)	60 x 60 x 90mm (2-1/4 x 2-1/4 x 3-1/2")
Weight	300gram (12oz)
Attachments	Owner's manual, Warranty card, 5mm ring, 6P connector & 4P connector for auto iris

Note : Design and specifications are subject to change without prior notice.  
Dimensions and weight are approximate.

## PROFILE

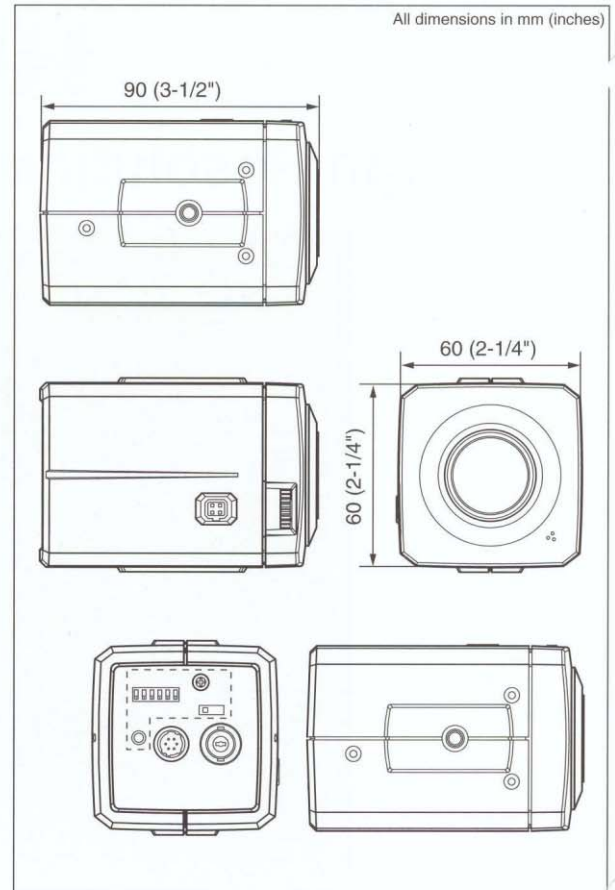

## View of the connectors

### 6P receptacle

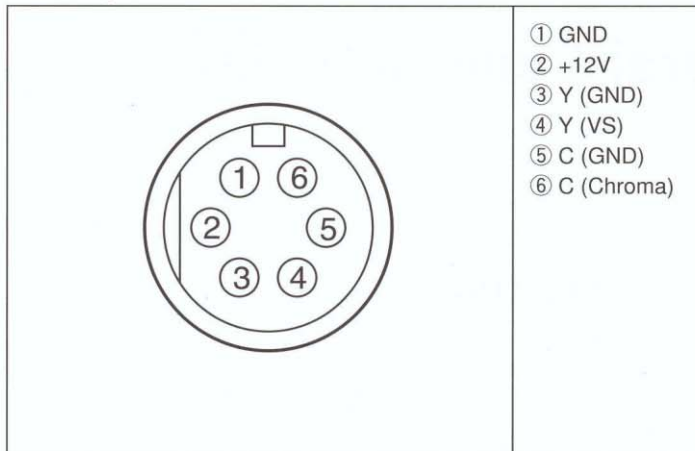

### 4P receptacle for auto iris

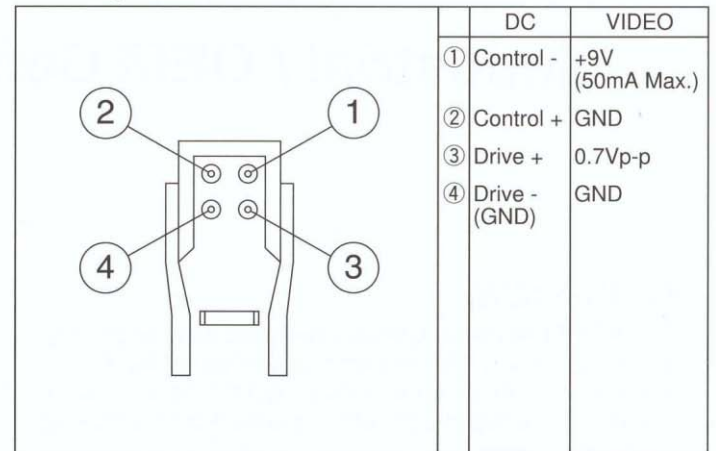

**ELMO ELMO CO., LTD.**

Additional technical information is available from any of the following subsidiary companies;

**ELMO Mfg. Corp.**  
1478 Old Country Road,  
Plainview, NY 11803-5034, U.S.A.  
Tel. 516-501-1400 Fax. 516-501-0429  
E-mail:elmo@elmousa.com  
Web:http://www.elmousa.com

**ELMO Canada Mfg. Corp.**  
44 West Drive, Brampton,  
Ontario, L6T 3T6, Canada  
Tel. 905-453-7880 Fax. 905-453-2391  
E-mail:info@elmocanada.com  
Web:http://www.elmocanada.com

6-14, Meizen-cho, Mizuho-ku,  
Nagoya, 467-8567, Japan  
E-Mail:foreign-div@elmo.co.jp

Distributed by

**ELMO (Europe) G.m.b.H.**  
Neanderstr 18,  
40233 Düsseldorf, Germany  
Tel. 0211-376051-53 Fax. 0211-376630  
E-mail:elmo@elmo.com  
Web:http://www.elmo.de/