

Capacity is listed as instant reference and depends on operation conditions.

SLIDE-OFF AIR NIPPER HORIZONTAL-TYPE Pat.

NY Series

Horizontal slide type enabling effective use of space
Convenient for mounting to chuck plate

- * Small and Light weight type. It is suitable for mounting of auto. machine, because main body height is low. Operation of chuck panel is not interrupted even when work is taken out.
- * Slide stroke can be adjusted. (0-3mm)
- * Slide part has no looseness, and has good durability.
- * External surface of main body is beautiful and excellent in rust prevention (Blue alumite finish).
- * Tube fitting and Hose nipple types available, enabling one-touch connection of air hose.
- * Blade opening control function is to be provided by special order.

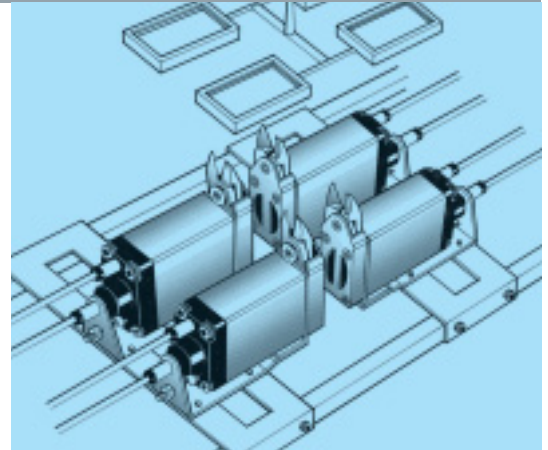

With hose nipple With tube fitting



GT-NY05



GT-NY10



GT-NY15

Blade is optional. Use three-port solenoid valve and foot valve (three-way).

EDP No.	Model No.	Cutting cap. ABS resin φ mm	Air consumption cm ³ /stroke	Working Air Pressure MPa	Pressure N	Weight lbf	Weight g	Slide range mm	Spec. of opening to hose
360646	GT-NY05	3.0	48	0.4~0.5	343	77	155	pull 0-3	W/hose nipple Hose I.D. φ 2mm
360647	GT-NY05R	3.0	48	0.4~0.5	343	77	155	push 0-3	W/hose nipple Hose I.D. φ 2mm
360648	GT-NY05-4	3.0	48	0.4~0.5	343	77	155	pull 0-3	W/tube fitting Hose I.D. φ 2mm × O.D. φ 4mm
360649	GT-NY05R-4	3.0	48	0.4~0.5	343	77	155	push 0-3	W/tube fitting Hose I.D. φ 2mm × O.D. φ 4mm
360652	GT-NY10	3.5	68	0.4~0.5	490	110	210	pull 0-3	W/hose nipple Hose I.D. φ 2mm
360656	GT-NY10R	3.5	68	0.4~0.5	490	110	210	push 0-3	W/hose nipple Hose I.D. φ 2mm
360660	GT-NY10-4	3.5	68	0.4~0.5	490	110	210	pull 0-3	W/tube fitting Hose I.D. φ 2mm × O.D. φ 4mm
360664	GT-NY10R-4	3.5	68	0.4~0.5	490	110	210	push 0-3	W/tube fitting Hose I.D. φ 2mm × O.D. φ 4mm
360672	GT-NY15	4.0	136	0.4~0.5	784	176	319	pull 0-3	W/hose nipple Hose I.D. φ 2mm
360673	GT-NY15R	4.0	136	0.4~0.5	784	176	319	push 0-3	W/hose nipple Hose I.D. φ 2mm
360674	GT-NY15-4	4.0	136	0.4~0.5	784	176	319	pull 0-3	W/tube fitting Hose I.D. φ 2mm × O.D. φ 4mm
360675	GT-NY15R-4	4.0	136	0.4~0.5	784	176	319	push 0-3	W/tube fitting Hose I.D. φ 2mm × O.D. φ 4mm
360680	GT-NY25	5.0	184	0.5~0.6	980	221	580	pull 0-5	W/hose nipple Hose I.D. φ 4mm
360681	GT-NY25R	5.0	184	0.5~0.6	980	221	580	push 0-5	W/hose nipple Hose I.D. φ 4mm
360682	GT-NY25-6	5.0	184	0.5~0.6	980	221	580	pull 0-5	W/tube fitting Hose I.D. φ 4mm × O.D. φ 6mm
360683	GT-NY25R-6	5.0	184	0.5~0.6	980	221	580	push 0-5	W/tube fitting Hose I.D. φ 4mm × O.D. φ 6mm

*Working air pressure...4-5kgf/cm²(57-71psi);5-6kgf/cm²(71-85psi) for GT-NY25,NY25R,NY25-6,NY25R-6

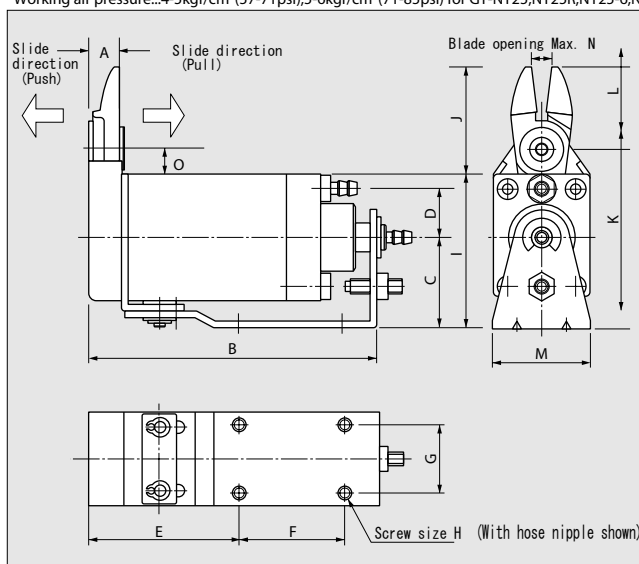

For mounting of exclusive ,automatic machines, check the product dimensions. (mm)

Model No.	A	B	C	D	E	F	G	H	I	J
GT-NY05	8.6	75.9	21.6	13.3	40.9	25	15	M4	39.1	30.5
GT-NY10	8.8	82.1	26.1	13.8	42.1	30	20	M4	44	31.6
GT-NY15	10.2	93	30	16	48	35	25	M4	50.5	34.5
GT-NY25	12.5	108.5	35	18.5	54.5	40	30	M5	58.5	41.5

Model No.	K	L	M	N	O
GT-NY05	47.6	22	23	4	8.5
GT-NY10	51.6	24	28	6	7.6
GT-NY15	58	27	33	8	7.5
GT-NY25	69	31	42	9	10.5

Blade length L and opening Max. N are the dimension adjusted for standard blade (AJ type).

CAUTION ! Please be sure to read through "For the safety use of the tools."